

# EX2300-C Compact Ethernet Switch

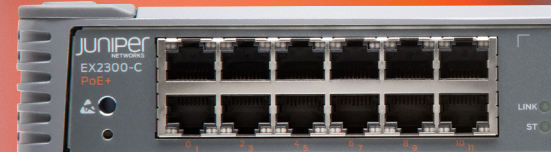

## Product Overview

The Juniper Networks EX2300-C Ethernet Switch offers an economical, entry-level solution in a compact, fanless form factor for access layer deployments in branches, retail, and workgroup environments.

To simplify network operations, the EX2300-C is hardware-ready<sup>1</sup> to act as a satellite device to support a Juniper Networks Junos Fusion Enterprise deployment, which can combine several wiring closets into one logical management platform. For smaller deployments, the EX2300 also supports Juniper Networks Virtual Chassis technology, allowing up to four interconnected switches to be managed as a single logical device, delivering a scalable, pay-as-you-grow solution for expanding networks.

## Product Description

The Juniper Networks® EX2300-C Ethernet Switch delivers a compact, silent, and power-efficient platform for low-density branch deployments and commercial access or enterprise workgroup environments outside the wiring closet.

Featuring 12 10/100/1000BASE-T access ports and two 10GbE uplink ports with and without Power over Ethernet (PoE/PoE+) in a fanless design, the EX2300-C switches deliver a powerful solution for supporting services such as unified communications, IP telephony, closed circuit television (CCTV), and other applications in office, classroom, hospitality, and other space and wiring-constrained environments. The key features of the EX2300-C switch include:

- Multiple hardware configurations:
  - 12 10/100/1000BASE-T access ports and two SFP+ 10GbE uplink ports
  - 12 10/100/1000BASE-T PoE/PoE+ access ports and two SFP+ 10GbE uplink ports
- IEEE 802.3at (PoE+) compliance, allowing a variety of devices to draw power from the switch through the access ports
- Ability to participate as a satellite device in a Juniper Networks Junos® Fusion Enterprise fabric
- Virtual Chassis support, allowing up to four switches to be interconnected and managed as a single logical device (optional license required)
- Energy Efficient Ethernet (EEE) support for GbE access ports
- Compact design featuring fanless and noiseless operation

## Architecture and Key Components

The fixed-configuration EX2300-C line of Ethernet switches delivers complete Layer 2 and basic Layer 3 switching capabilities to satisfy the low-density branch and low-density wiring closet connectivity requirements of today's high-performance business needs. The EX2300-C models extend that reach into workgroup environments that reside outside the wiring closet, including branch offices, retail access applications, education, hospitality, and other locations where the switch is deployed in open areas inside a building.

Two versions are available. The EX2300-C-12T offers 12 front panel 10/100/1000BASE-T access ports and two SFP+ 10GbE uplink ports. The EX2300-C-12P offers 12 front panel 10/100/1000BASE-T IEEE 802.3af/IEEE 802.3at (PoE/PoE+) access ports, which can be used for powering networked devices such as telephones, video cameras, multiple radio IEEE 802.11ac wireless LAN (WLAN) access points, and videophones in converged network environments. In addition, the EX2300-C-12P has two SFP+ 10GbE uplink ports.

The uplink ports can be used to connect to higher-layer devices such as aggregation switches or routers. The uplink ports can also be configured as Virtual Chassis interfaces and connected via standard 10GbE interfaces. A fixed internal power supply ensures operational simplicity.

<sup>1</sup> Software to come in future



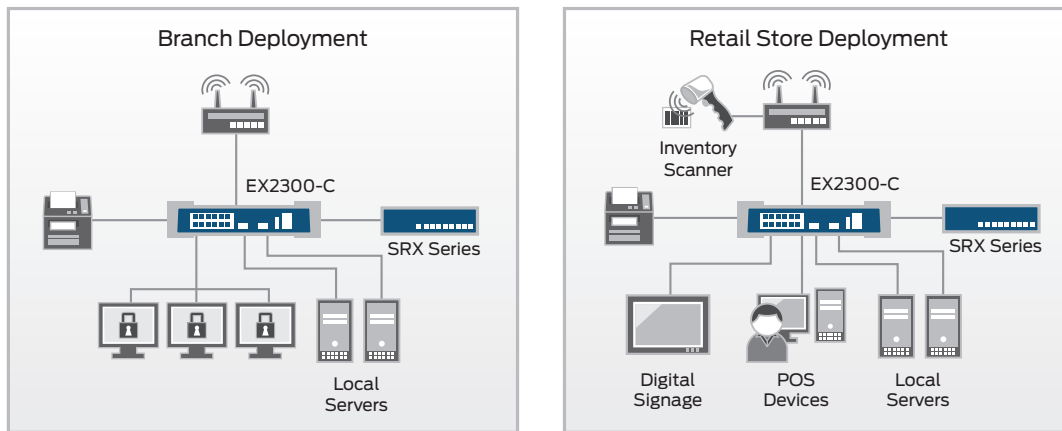

Figure 1: EX2300-C branch and retail store deployments.

## Junos Fusion Enterprise Technology

Junos Fusion Enterprise technology provides automated network configuration and simplifies scalability for medium to large enterprise networks. Using the Juniper Networks EX9200 line of programmable switches as aggregation devices and EX2300-C switches as satellite nodes, Junos Fusion Enterprise technology can be deployed across a building (or multiple buildings) to connect large numbers of switches in a fabric that can be managed as a single device.

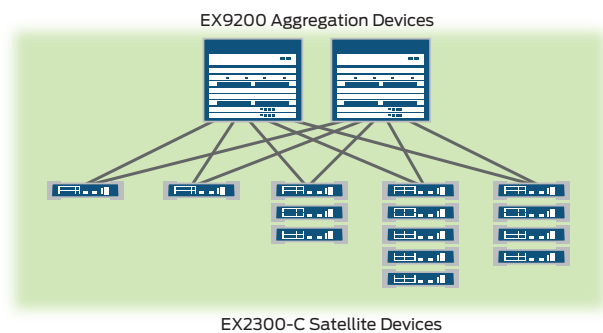

Figure 2: Junos Fusion Enterprise deployment using EX2300-C switches as satellite devices

With Junos Fusion Enterprise technology, enterprises can reduce network complexity and operational costs by collapsing underlying network elements into a single logical point of control from Juniper Networks Junos operating system-based Juniper routing and switching platforms. It is designed for customers who need to cost-effectively deploy numerous switch ports throughout their enterprise campus network and manage them all from a central device. In addition, existing EX2300-C switches can be easily added to a Junos Fusion Enterprise deployment with a simple software upgrade, offering full investment protection.

In Junos Fusion Enterprise deployments, satellite devices do not require to be individually connected to aggregation devices. Up to four satellite devices can be interconnected via standard 10GbE interfaces to form a “cluster,” which, in turn, can be connected

to the aggregation device(s) over a pair of fiber uplinks. Satellite devices or clusters can also be dual-homed or single-homed to the aggregation devices.

In Junos Fusion Enterprise deployments, satellite devices forward all traffic to the aggregation device, enabling network administrators to monitor and manage the entire enterprise campus building from a single device. Features such as PoE/PoE+, LLDP-MED, and 802.1x are also supported in Junos Fusion Enterprise architectures to help meet enterprise campus requirements.

## Virtual Chassis Technology

The EX2300-C supports Juniper’s unique Virtual Chassis technology, enabling up to four interconnected EX2300-C switches to be managed as a single logical device and delivering a scalable, pay-as-you-grow solution for expanding network environments. The EX2300-C can also be connected to an existing Virtual Chassis configuration composed of EX2300 switches.

While EX2300-C switches can be interconnected over either of the two front panel 10GbE uplink ports, these ports can also be configured as 1GbE uplinks to aggregation devices by disabling the Virtual Chassis technology.

When deployed in a Virtual Chassis configuration, the EX2300-C switches elect a primary and a backup switch based on a set of preconfigured policies or criteria. The master switch automatically creates and updates the switching and optional routing tables on all other Virtual Chassis switch members. Switches can be added to or removed from the Virtual Chassis configuration without service disruption.

EX2300-C Virtual Chassis configurations operate as highly resilient unified systems, providing simplified management using a single IP address, single telnet/SSH session, single command-line interface (CLI), automatic version checking, and automatic configuration. The EX2300-C switches are also capable of local switching, so packets coming into a port destined for another port on the same switch do not have to traverse the Virtual Chassis, increasing forwarding capacities.

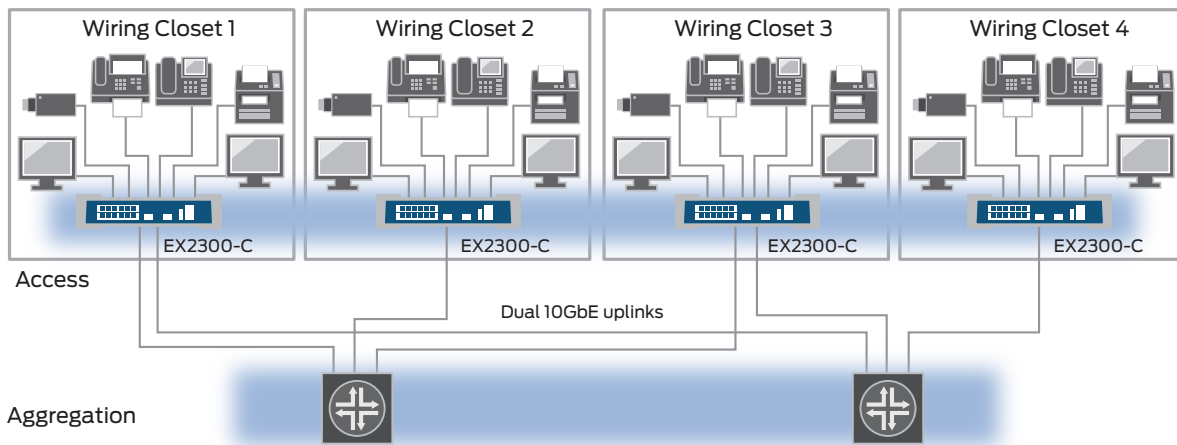

Figure 3: When deployed in a Virtual Chassis configuration, up to four EX2300-C switches can operate as a single, logical device.

EX2300-C Virtual Chassis configurations implement the same slot/module/port numbering schema as other Juniper Networks chassis-based products, providing true chassis-like operations. By using a consistent operating system and a single configuration file, all switches in a Virtual Chassis configuration are treated as a single device, simplifying overall system maintenance and management.

### Simplified Management and Operations

Junos Fusion Enterprise dramatically simplifies EX2300-C management by enabling a large number of the switches to be managed from a single management interface when deployed as satellite devices. With features such as plug-and-play deployment and rolling software upgrades, Junos Fusion Enterprise eliminates the need to individually manage every access switch in the enterprise network, leading to lower operational costs and overall lower TCO.

Virtual Chassis technology simplifies network management for smaller deployments. Up to four interconnected EX2300-C switches can be managed as a single device utilizing a single Junos OS image and a single configuration file, reducing the overall number of units to monitor and manage. When the Junos OS is upgraded on the master switch in an EX2300-C Virtual Chassis configuration, the software is automatically upgraded on all other member switches at the same time.

Dedicated front panel RJ-45 and USB console ports offer flexible out-of-band management options, while a front panel USB port can be used to easily upload the Juniper Networks Junos operating system and configuration files. All front panel access and uplink ports have dedicated link status and link activity LEDs. In addition, a series of front panel LEDs offer system status information with a button that allows users to toggle through four different modes for reporting speed (SPD), duplex mode (DX), administrative status (EN), and PoE status (PoE). A fixed internal power supply ensures operational simplicity.

### Easy Provisioning

Auto-configuration and Auto-Image Install features allow the switches to be configured and imaged over the network using the Dynamic Host Configuration Protocol (DHCP) message exchange process. These features eliminate the need to stage devices prior to deployment, dramatically reducing operational expenses. Auto-configuration and Auto Image Install allow new branches and retail stores to rapidly deploy their networks, and they also enable software upgrades and security fixes to be performed at the touch of a button. A zero touch provisioning (ZTP) feature allows a DHCP server to push configuration details and software images to multiple switches at boot-up time.

Juniper Networks Junos Space Network Director can manage the EX2300-C as a standalone switch as well as satellite devices in a Junos Fusion Enterprise deployment.

### Features and Benefits

The EX2300-C model switches include a number of features that make them ideal for low-density, open space deployments.

#### Compact Form Factor

At 10.98 inches wide and 9.4 inches deep, EX2300-C switches can be easily and discreetly installed on desktops, on or under shelves, or on walls. An optional magnetic mounting pad is available for securing the EX2300-C switches to metal surfaces. Rack-mount kits are also available for installing the switches in standard 19-inch wiring racks. Wall mounting can be done using the flexible mounting slots on the bottom of the chassis to attach to the screws on the wall.

#### Silent Operation

The EX2300-C switches are fanless, resulting in a silent operation suitable for deployments in workgroup areas. The fanless design also reduces power consumption and improves mean time between failures (MTBF) by eliminating moving parts.

## Low Power

The fanless design reduces the power consumed by the EX2300-C switches. Energy Efficient Ethernet (EEE) ports ensure low power consumption when the network link is idle.

## Access Security

Working as an enforcement point within the Access Policy Infrastructure, the EX2300-C provides standards-based 802.1X port-level access control as well as L2-L4 policy enforcement based on user identity, location, device, or a combination of these. If access is granted, the switch assigns the user to a specific VLAN based on authorization levels.

The EX2300-C also provides a full complement of port security features, including DHCP snooping, dynamic ARP inspection (DAI), and media access control (MAC) limiting to defend against internal and external spoofing, and man-in-the-middle and denial-of-service (DoS) attacks.

## Physical Security

Security slots on either side of the switch accept locking devices that physically secure switches, preventing them from being easily removed in open space or unsecured environments.

## PoE/PoE+ Power

The EX2300-C-12P switch delivers power for supporting networked devices such as telephones, video cameras, IEEE 802.11n WLAN access points, and videophones. It supports the

IEEE 802.3af PoE standard, as well as IEEE 802.3at PoE+ with a budget of 124 watts. At maximum power, the 12-port EX2300-C-12P can provide the full 15.4 watts of Class 3 PoE to a maximum of eight ports simultaneously, and the full 30 watts of PoE+ to a maximum of four ports simultaneously. Attached devices draw the necessary power until the PoE power budget is exhausted.

## Junos Operating System

The EX2300-C switches run the same Junos OS that is used by other Juniper Networks EX Series Ethernet Switches, QFX Series Switches, Juniper Routers, Juniper SRX Firewalls, and the Juniper NFX Series Network Services Platform. By using a common operating system, Juniper delivers a consistent implementation and operation of control plane features across all products.

## Enhanced Limited Lifetime Warranty

The EX2300-C switches include an enhanced limited lifetime hardware warranty that provides next business day advance hardware replacement for as long as the original purchaser owns the product. The warranty includes lifetime software updates, advanced shipping of spares within one business day, and 24x7 Juniper Networks Technical Assistance Center (JTAC) support for 90 days after the purchase date. Power supplies and fan trays are covered for a period of five years. For complete details, please visit [www.juniper.net/support/warranty](http://www.juniper.net/support/warranty).

## Product Options

Table 1: EX2300-C Ethernet Switch Models

Model	Access Port Configuration	Uplink Ports	PoE+ Capable Ports	Height	PoE+ Budget	Power Supply Rating
EX2300-C-12T	12-port 10/100/1000BASE-T	Two SFP/SFP+ ports	0	1 RU	N/A	40 W AC
EX2300-C-12P	12-port 10/100/1000BASE-T	Two SFP/SFP+ ports	12	1 RU	124 W	170 W AC



EX2300-C

## Physical Specifications

### Power Options

- Fixed internal power supply (AC)

Model	Max. System Power Consumption (Input Power without PoE)	Total PoE Power Budget
EX2300-C-12T	20 W AC	0
EX2300-C-12P	24 W AC	124W

### Dimensions (W x H x D)

- EX2300-C-12T: 10.98 x 1.72 x 9.4 in (27.9 x 4.4 x 23.9 cm)
- EX2300-C-12P: 10.98 x 1.72 x 9.4 in (27.9 x 4.4 x 23.9 cm)

### Backplane

- 40 Gbps Virtual Chassis interconnect to link up to four switches as a single logical device

### System Weight

- EX2300-C-12T: 5.45 lb (2.48 kg)
- EX2300-C-12P: 6.99 lb (3.17 kg)

### Environmental Ranges

- Operating temperature: 32° to 104° F (0° to 40° C)<sup>1,2</sup>
- Storage temperature: -40° to 158° F (-40° to 70° C)
- Operating altitude: up to 5,000 ft (1524 m)
- Nonoperating altitude: up to 16,000 ft (4877 m)
- Relative humidity operating: 10% to 85% (noncondensing)
- Relative humidity nonoperating: 0% to 95% (noncondensing)

### Cooling

- Fanless operation

## Hardware Specifications

### Switching Engine Model

- Store and forward

### DRAM

- 2 GB with ECC

### Flash

- 2 GB

### CPU

- 1.25 GHz ARM CPU

### GbE port density per system

- 14 (12 access ports + 2 uplink ports)

### Physical Layer

- Physical port redundancy: Redundant trunk group (RTG)
- Cable diagnostics for detecting cable breaks and shorts

- Auto medium-dependent interface/medium-dependent interface crossover (MDI/MDIX) support
- Port speed downshift/setting maximum advertised speed on 10/100/1000BASE-T ports
- Digital optical monitoring for optical ports

### Packet-Switching Capacities (Maximum with 64-Byte Packets)

- 64 Gbps

## Software Specifications

### Layer 2/Layer 3 Throughput (Mpps) (Maximum with 64 Byte Packets)

- 47 Mpps (wire speed)

### Layer 2 Features

- Maximum MAC addresses in hardware: 16,000
- Jumbo frames: 9216 bytes
- Number of VLANs supported: 4093
- Range of possible VLAN IDs: 1-4094
- Port-based VLAN
- MAC-based VLAN
- Voice VLAN
- IEEE 802.1ak: Multiple VLAN Registration Protocol (MVRP)
- Compatible with Per-VLAN Spanning Tree Plus (PVST+)
- RVI (Routed VLAN Interface)
- IEEE 802.1AB: Link Layer Discovery Protocol (LLDP)
- LLDP-MED with VoIP integration
- IEEE 802.1br Bridge Port Extension
- IEEE 802.1D: Spanning Tree Protocol
- IEEE 802.1p: CoS Prioritization
- IEEE 802.1Q: VLAN Tagging
- IEEE 802.1Q-in-Q: VLAN Stacking
- IEEE 802.1s: Multiple Spanning Tree Protocol (MSTP)
- Number of MST instances supported: 64
- IEEE 802.1w: Rapid Spanning Tree Protocol (RSTP)
- IEEE 802.1X: Port Access Control
- IEEE 802.3: 10BASE-T
- IEEE 802.3u: 100BASE-TX
- IEEE 802.3ab: 1000BASE-T
- IEEE 802.3z: 1000BASE-X
- IEEE 802.3af: PoE
- IEEE 802.3at: PoE+
- IEEE 802.3ad: Link Aggregation Control Protocol (LACP)
- IEEE 802.3ah: Ethernet in the First Mile (EFM)

### Layer 3 Features: IPv4

- Maximum number of ARP entries: 1,024
- Maximum number of IPv4 unicast routes in hardware: 512 prefixes; 4,096 host routes
- Maximum number of IPv4 multicast routes in hardware: 2,048 groups; 2,048 multicast routes

<sup>1</sup> To support operating temperature ranges beyond 40° C at altitudes up to 5,000 feet, extended temperature-range SFPs should be used when fiber uplinks are being utilized.

<sup>2</sup> Use extended temperature-grade transceivers for optical reach of ER and ZR.

- Routing Protocols: RIP v1/v2, OSPF v1/v2 (with 4 active interfaces)
- Static routing
- Routing policy
- Bidirectional Forwarding Detection (BFD) with slow timers (> 3 sec)
- IP directed broadcast

#### Layer 3 Features: IPv6

- Maximum number of Neighbor Discovery (ND) entries: 750
- Maximum number of IPv6 unicast routes in hardware: 128 prefixes; 2,048 host routes
- Maximum number of IPv6 multicast routes in hardware: 1,024 groups; 1,024 multicast routes
- Neighbor discovery, system logging, Telnet, SSH, SNMP, Network Time Protocol (NTP), Domain Name System (DNS)
- Static routing
- Routing protocols: RIPng, OSPF v3

#### Access control lists (ACLs) (Junos OS firewall filters)

- Port-based ACL (PACL)—ingress
- VLAN-based ACL (VAACL)—ingress and egress
- Router-based ACL (RAACL)—ingress and egress
- ACL entries (ACE) in hardware per system: 1500
- ACL counter for denied packets
- ACL counter for permitted packets
- Ability to add/remove/change ACL entries in middle of list (ACL editing)
- L2-L4 ACL

#### Access Security

- MAC limiting
- Allowed MAC addresses—configurable per port
- Sticky MAC (persistent MAC address learning)
- Dynamic ARP inspection (DAI)
- Proxy ARP
- Static ARP support
- DHCP snooping
- 802.1X port-based
- 802.1X multiple supplicants
- 802.1X with VLAN assignment
- 802.1X with authentication bypass access (based on host MAC address)
- 802.1X with VoIP VLAN support
- 802.1X dynamic access control list (ACL) based on RADIUS attributes
- 802.1X Supported EAP types: Message Digest 5 (MD5), Transport Layer Security (TLS), Tunneled Transport Layer Security (TTLS), Protected Extensible Authentication Protocol (PEAP)
- Captive Portal
- Static MAC authentication
- MAC-RADIUS

- Control plane DoS protection
- Fallback Authentication
- Trusted Network Connect (TNC) certified

#### High Availability

- Link Aggregation
- 802.3ad (LACP) support:
  - Number of LAGs supported: 128
  - Maximum number of ports per LAG: 8
- Tagged ports support in LAG
- Uplink failure detection

#### Quality of Service (QoS)

- Layer 2 QoS
- Layer 3 QoS
- Ingress policing: 2 rate 3 color
- Hardware queues per port: 8
- Scheduling methods (egress): Strict Priority (SP), shaped-deficit weighted round-robin (SDWRR)
- 802.1p: DSCP/IP precedence trust and marking
- L2-L4 classification criteria: Interface, MAC address, Ethertype, 802.1p, VLAN, IP address, DSCP/IP precedence, TCP/UDP port numbers
- Congestion avoidance capabilities: Tail drop

#### Multicast

- Internet Group Management Protocol (IGMP) snooping entries: 1000
- IGMP: v1, v2, v3
- IGMP snooping
- PIM sparse mode (PIM SM), PIM source-specific multicast (PIM SSM), PIM dense mode (PIM DM)

#### Services and Manageability

- Junos OS command-line interface (CLI)
- Web interface (J-Web)
- Out-of-band management: Serial, 10/100BASE-T Ethernet
- ASCII configuration
- Rescue configuration
- Configuration rollback
- Image rollback
- Element management tools: Juniper Networks Junos Space Network Management Platform
- Real-time performance monitoring (RPM)
- SNMP: v1, v2c, v3
- Remote monitoring (RMON) (RFC 2819) Groups 1, 2, 3, 9
- Network Time Protocol (NTP)
- DHCP server
- DHCP client and DHCP proxy
- DHCP relay and helper
- RADIUS authentication
- SSHv2
- Secure copy
- HTTP/HTTPs

- DNS resolver
- System logging
- Temperature sensor
- Configuration backup via FTP/secure copy
- Interface range

#### Supported RFCs

- RFC 768 UDP
- RFC 783 Trivial File Transfer Protocol (TFTP)
- RFC 791 IP
- RFC 792 Internet Control Message Protocol (ICMP)
- RFC 793 TCP
- RFC 826 ARP
- RFC 854 Telnet client and server
- RFC 894 IP over Ethernet
- RFC 903 Reverse ARP (RARP)
- RFC 906 Bootstrap Loading using TFTP
- RFC 951, 1542 BootP
- RFC 1027 Proxy ARP
- RFC 1058 RIP v1
- RFC 1122 Host requirements
- RFC 1256 IPv4 ICMP Router Discovery (IRDP)
- RFC 1492 TACACS+
- RFC 1519 Classless Interdomain Routing (CIDR)
- RFC 1591 Domain Name System (DNS)
- RFC 1812 Requirements for IP Version 4 routers
- RFC 2030 Simple Network Time Protocol (SNTP)
- RFC 2068 HTTP/1.1
- RFC 2131 BOOTP/DHCP relay agent and DHCP server
- RFC 2138 RADIUS Authentication
- RFC 2139 RADIUS Accounting
- RFC 2267 Network Ingress Filtering
- RFC 2453 RIP v2
- RFC 2474 DiffServ Precedence, including 8 queues/port
- RFC 2597 DiffServ Assured Forwarding (AF)
- RFC 2598 DiffServ Expedited Forwarding (EF)
- RFC 2710 Multicast Listener Discovery Version (MLD) for IPv6
- RFC 2925 Definitions of Managed Objects for Remote Ping, Traceroute, and Lookup Operations
- RFC 3176 sFlow
- RFC 3579 RADIUS Extensible Authentication Protocol (EAP) support for 802.1X
- RFC 3810 Multicast Listener Discovery Version 2 (MLDv2) for IPv6
- RFC 5176 Dynamic Authorization Extensions to RADIUS
- LLDP Media Endpoint Discovery (LLDP-MED), ANSI/TIA-1057, draft 08

#### Supported MIBs

- RFC 1155 Structure of Management Information (SMI)
- RFC 1157 SNMPv1
- RFC 1212, RFC 1213, RFC 1215 MIB-II, Ethernet-like MIB, and

#### TRAPs

- RFC 1493 Bridge MIB
- RFC 1643 Ethernet MIB
- RFC 1724 RIPv2 MIB
- RFC 1905 RFC 1907 SNMP v2c, SMIv2, and Revised MIB-II
- RFC 1981 Path MTU Discovery for IPv6
- RFC 2011 SNMPv2 Management Information Base for the IP using SMIv2
- RFC 2012 SNMPv2 Management Information Base for the transmission Control Protocol using SMIv2
- RFC 2013 SNMPv2 Management Information Base for the User Datagram Protocol using SMIv2
- RFC 2096 IPv4 Forwarding Table MIB
- RFC 2287 System Application Packages MIB
- RFC 2460 IPv6 Specification
- RFC 2464 Transmission of IPv6 Packets over Ethernet Networks
- RFC 2570-2575 SNMPv3, User-based Security, Encryption, and Authentication
- RFC 2576 Coexistence between Version 1, Version 2, and Version 3 of the Internet-standard Network Management Framework
- RFC 2578 SNMP Structure of Management Information MIB
- RFC 2579 SNMP Textual Conventions for SMIv2
- RFC 2665 Definitions of Managed Objects for the Ethernet-like Interface Types
- RFC 2819 RMON MIB
- RFC 2863 The Interfaces Group MIB
- RFC 2922 LLDP MIB
- RFC 2925 Definitions of Managed Objects for Remote Ping, Traceroute, and Lookup Operations
- RFC 3413 SNMP Application MIB
- RFC 3414 User-based Security Model for SNMPv3
- RFC 3415 View-based Access Control Model (VACM) for SNMP
- RFC 3484 Default Address Selection for IPv6
- RFC 3621 PoE-MIB (PoE switches only)
- RFC 4188 STP and Extensions MIB
- RFC 4213 Basic Transition Mechanisms for IPv6 Hosts and Routers
- RFC 4291 IPv6 Addressing Architecture
- RFC 4363 Definitions of Managed Objects for Bridges with Traffic Classes, Multicast Filtering, and VLAN Extensions
- RFC 4443 ICMPv6 for the IPv6 Specification
- RFC 4861 Neighbor Discovery for IPv6
- RFC 4862 IPv6 Stateless Address Autoconfiguration
- Draft - blumenthal - aes - usm - 08
- Draft - reeder - snmpv3 - usm - 3desede -0

#### Troubleshooting

- Debugging: CLI via console, telnet, or SSH
- Diagnostics: Show and debug command statistics
- Traffic mirroring (port)

- Traffic mirroring (VLAN)
- Filter-based mirroring
- Mirroring destination ports per system: 4
- LAG port monitoring
- Multiple destination ports monitored to 1 mirror (N:1)
- Maximum number of mirroring sessions: 4
- Mirroring to remote destination (over L2): 1 destination VLAN
- Encapsulated Remote Switched Port Analyzer (ERSPAN)
- IP tools: Extended ping and trace
- Juniper Networks commit and rollback

## Safety Certifications

- UL-UL60950-1 (Second Edition)
- C-UL to CAN/CSA 22.2 No.60950-1 (Second Edition)
- TUV/GS to EN 60950-1 (Second Edition)
- CB-IEC60950-1 (Second Edition with all country deviations)
- EN 60825-1 (Second Edition)

## Electromagnetic Compatibility Certifications

- FCC 47CFR Part 15 Class A
- EN 55022 Class A
- ICES-003 Class A
- VCCI Class A
- AS/NZS CISPR 22 Class A
- CISPR 22 Class A
- EN 55024
- EN 300386
- CE

## Telecom Quality Management

- TL9000

## Telco

- CLEI code

## Noise Specifications

- 0 db (fanless)

## Warranty

- Enhanced limited lifetime switch hardware warranty

## Juniper Networks Services and Support

Juniper Networks is the leader in performance-enabling services that are designed to accelerate, extend, and optimize your high-performance network. Our services allow you to maximize operational efficiency while reducing costs and minimizing risk, achieving a faster time to value for your network. Juniper Networks ensures operational excellence by optimizing the network to maintain required levels of performance, reliability, and availability. For more details, please visit [www.juniper.net/us/en/products-services](http://www.juniper.net/us/en/products-services).

## Ordering Information

Product Number	Description
<b>Switches</b>	
EX2300-C-12T	EX2300 Compact Fanless 12-port 10/100/1000BASE-T, 2 x 1/10GbE SFP/SFP+ (optics sold separately)
EX2300-C-12T-VC	EX2300 Compact Fanless 12-port 10/100/1000BASE-T, 2 x 1/10GbE SFP/SFP+ with Virtual Chassis License (optics sold separately)
EX2300-C-12P	EX2300 Compact Fanless 12-port 10/100/1000BASE-T PoE+, 2 x 1/10GbE SFP/SFP+ (optics sold separately)
EX2300-C-12P-VC	EX2300 Compact Fanless 12-port 10/100/1000BASE-T PoE+, 2 x 1/10GbE SFP/SFP+ with Virtual Chassis License (optics sold separately)
EX2300-C-12T-TAA	EX2300 TAA Compact Fanless 12-port 10/100/1000BASE-T, 2 x 1/10GbE SFP/SFP+ (optics sold separately)
EX2300-C-12P-TAA	EX2300 TAA Compact Fanless 12-port 10/100/1000BASE-T PoE+, 2 x 1/10GbE SFP/SFP+ (optics sold separately)
<b>Accessories</b>	
EX-CBL-CON-USB	Console cable with USB Type A and mini-B connectors
EX2300-C-CBL-GRD	Cable guard
EX2300-C-MGNT-MNT	Magnet mount
EX2300-C-RMK	Rack-mount kit
<b>Licenses</b>	
EX2300-VC	EX2300 Virtual Chassis License
EX-12-EFL	Enhanced Feature License—includes licenses for IPv4 routing (OSPF v2/v3, IGMP v1/v2/v3, VRRP, BFD, and IPv4 Virtual Router support), IPv6 routing (RIPng, OSPF v3, VRRP v6, MSDP, and PIM), and Real-Time Performance Monitoring (RPM)
<b>Optics</b>	
EX-SFP-10GE-USR	SFP+ 10-Gigabit Ethernet Ultra Short Reach Optics, 850 nm for 10m on OM1, 20m on OM2, 100m on OM3 multimode fiber
EX-SFP-10GE-DAC-1M	SFP+ 10-Gigabit Ethernet Direct Attach Copper (twinax copper cable), 1m
EX-SFP-10GE-SR	SFP+ 10GBASE-SR 10-Gigabit Ethernet Optics, 850 nm for up to 300m transmission on MMF
EX-SFP-10GE-LR	SFP+ 10-Gigabit Ethernet Direct Attach Copper (twinax copper cable), 3m
EX-SFP-10GE-DAC-3M	SFP+ 10-Gigabit Ethernet Direct Attach Copper (twinax copper cable), 3m
EX-SFP-10GE-DAC-5M	SFP+ 10-Gigabit Ethernet Direct Attach Copper (twinax copper cable), 5m
EX-SFP-1GE-SX	SFP 1000BASE-SX; LC connector; 850 nm; 550m reach on multimode fiber
EX-SFP-1GE-SX-ET	Extended Temperature SFP 1000BASE-SX; LC connector; 850 nm; 550m reach on multimode fiber
EX-SFP-1GE-LX	SFP 1000BASE-LX; LC connector; 1310 nm; 10 km reach on single-mode fiber
EX-SFP-10GE-ER	SFP+ 10GBASE-ER 10-Gigabit Ethernet Optics, 1550 nm for 40 km transmission on single-mode fiber

Product Number	Description
EX-SFP-IGE-LH	SFP 1000BASE-LH Gigabit Ethernet Optics, 1550 nm for 70 km transmission on single-mode fiber
EX-SFP-IGE-T	SFP 10/100/1000BASE-T Copper Transceiver Module for up to 100m transmission on Category <sup>1</sup>
EX-SFP-IGE-LX40K	SFP 1000BASE-LX Gigabit Ethernet Optics, 1310 nm for 40 km transmission on single-mode fiber
EX-SFP-GE10KT13R14	SFP 1000BASE-BX Gigabit Ethernet Optics, Tx 1310 nm/Rx 1490 nm for 10 km transmission on single strand of single-mode fiber
EX-SFP-GE10KT14R13	SFP 1000BASE-BX Gigabit Ethernet Optics, Tx 1490 nm/Rx 1310 nm for 10 km transmission on single strand of single-mode fiber
EX-SFP-GE10KT13R15	SFP 1000BASE-BX Gigabit Ethernet Optics, Tx 1310 nm/Rx 1550 nm for 10 km transmission on single strand of single-mode fiber
EX-SFP-GE10KT15R13	SFP 1000BASE-BX Gigabit Ethernet Optics, Tx 1550 nm/Rx 1310 nm for 10 km transmission on single strand of single-mode fiber
EX-SFP-GE40KT13R15	SFP 1000BASE-BX Gigabit Ethernet Optics, Tx 1310 nm/Rx 1550 nm for 40 km transmission on single strand of single-mode fiber
EX-SFP-GE40KT15R13	SFP 1000BASE-BX Gigabit Ethernet Optics, Tx 1550 nm/Rx 1310 nm for 40 km transmission on single strand of single-mode fiber

<sup>1</sup> Each switch comes with a RJ-45-to-DB-9 serial port adapter, power cord retainer, and four rubber feet. Each system also ships with a power cord for the country to which it is shipped.

Product Number	Description
EX-SFP-GE80KCW1470	SFP Gigabit Ethernet CWDM, LC connector; 1470 nm, 80 km reach on single-mode fiber
EX-SFP-GE80KCW1490	SFP Gigabit Ethernet CWDM, LC connector; 1490 nm, 80 km reach on single-mode fiber
EX-SFP-GE80KCW1510	SFP Gigabit Ethernet CWDM, LC connector; 1510 nm, 80 km reach on single-mode fiber
EX-SFP-GE80KCW1530	SFP Gigabit Ethernet CWDM, LC connector; 1530 nm, 80 km reach on single-mode fiber
EX-SFP-GE80KCW1550	SFP Gigabit Ethernet CWDM, LC connector; 1550 nm, 80 km reach on single-mode fiber
EX-SFP-GE80KCW1570	SFP Gigabit Ethernet CWDM, LC connector; 1570 nm, 80 km reach on single-mode fiber
EX-SFP-GE80KCW1590	SFP Gigabit Ethernet CWDM, LC connector; 1590 nm, 80 km reach on single-mode fiber
EX-SFP-GE80KCW1610	SFP Gigabit Ethernet CWDM, LC connector; 1610 nm, 80 km reach on single-mode fiber

## About Juniper Networks

Juniper Networks challenges the status quo with products, solutions and services that transform the economics of networking. Our team co-innovates with customers and partners to deliver automated, scalable and secure networks with agility, performance and value. Additional information can be found at [Juniper Networks](#) or connect with Juniper on [Twitter](#) and [Facebook](#).

Corporate and Sales Headquarters  
 Juniper Networks, Inc.  
 1133 Innovation Way  
 Sunnyvale, CA 94089 USA  
 Phone: 888.JUNIPER (888.586.4737)  
 or +1.408.745.2000  
 Fax: +1.408.745.2100  
[www.juniper.net](http://www.juniper.net)

APAC and EMEA Headquarters  
 Juniper Networks International B.V.  
 Boeing Avenue 240  
 1119 PZ Schiphol-Rijk  
 Amsterdam, The Netherlands  
 Phone: +31.0.207.125.700  
 Fax: +31.0.207.125.701



Copyright 2016 Juniper Networks, Inc. All rights reserved. Juniper Networks, the Juniper Networks logo, and Junos are registered trademarks of Juniper Networks, Inc. in the United States and other countries. All other trademarks, service marks, registered marks, or registered service marks are the property of their respective owners. Juniper Networks assumes no responsibility for any inaccuracies in this document. Juniper Networks reserves the right to change, modify, transfer, or otherwise revise this publication without notice.

**JUNIPER**  
 NETWORKS